

Model 2600

Victor mobile lift

For intensive and super fast use



SUREHANDS®



- Lifts twice as fast
- Designed for intensive use
- Electrically adjustable base
- Usable in combination with various spreader bars, slings and Body Support
- Lifts from floor to high surfaces
- Aluminium construction for easy care
- Exchangeable battery box or direct charging
- Optional digital scale

Lift & Care systems for people with reduced mobility

www.surehands.com

Victor mobile lift

● Dimensions (mm / inch)

A	1725	67.91
B	660	25.98
B1	1150	45.28
H	775	30.51
H1	1530	60.24
H2	2240	88.19
h	120	4.72
C	440	17.32
C1	170	6.69
C2	620	24.41
L	1275	50.20
E	54	2.13

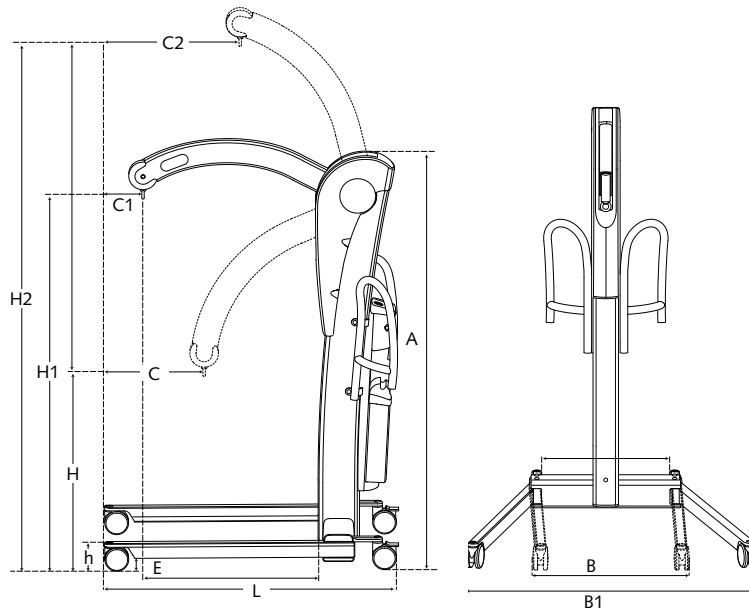

● Specifications

Mobile hoist

Construction.....aluminium; gloss finish
 Covers.....ABS
 Weight.....58 kg / 127.87 Lbs
 Motor/actuator.....24 Vdc. 13 A
electric/hydraulic
 Weight batterybox.....6.2 kg / 13.67 Lbs
 Safe working load.....225 kg / 500 Lbs
 Emergency switch.....present
 Wheels:.....front ø 100 mm / 3.94 Inch
rear ø 100 mm / 3.94 Inch with brakes
 Emergency down.....mechanical
 Noise.....66 dBA
 Battery-indicator.....acoustic
 Batteries.....2x12 Vdc; 7.2 Ah

Charger- in:.....0.9 A 100 - 240 VAC
50 - 60 Hz, klasse II
 Charger- out:.....24 Vdc
Max 1.3 A
 Number of lifts when fully charged.....160 lifts with 90 kg / 198.42 Lbs
distance 500 mm / 19.69 Inch
 Safety class.....IPx0
 Charging time after signal.....4 hours
 Wall-mount charger.....optional
 Extra battery box.....optional

● Speeds

Speed up

without load.....5.2 cm/sec / 2.05 Inch/sec
 load 90 kg / 200 Lbs.....4.9 cm/sec / 1.93 Inch/sec
 load 225 kg / 500 Lbs.....4.6 cm/sec / 1.81 Inch/sec

Speed down

without load.....4.9 cm/sec / 1.93 Inch/sec
 load 90 kg / 200 Lbs.....5.7 cm/sec / 2.24 Inch/sec
 load 225 kg / 500 Lbs.....5.7 cm/sec / 2.24 Inch/sec

Local Representative

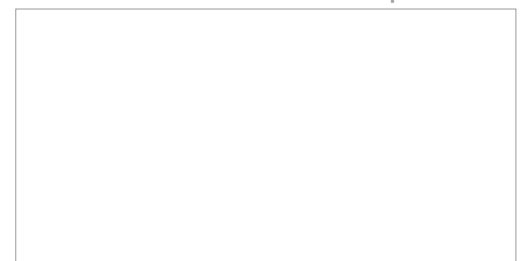

Lift & Care® is a registered trademark of T.F. Herceg, Inc. dba SUREHANDS LIFT & CARE SYSTEMS.

© 17-04-2020 • Handi-Move • v 3.3