

Model 2540

Track-to-Track™ motor

Versatility and portability



SUREHANDS®

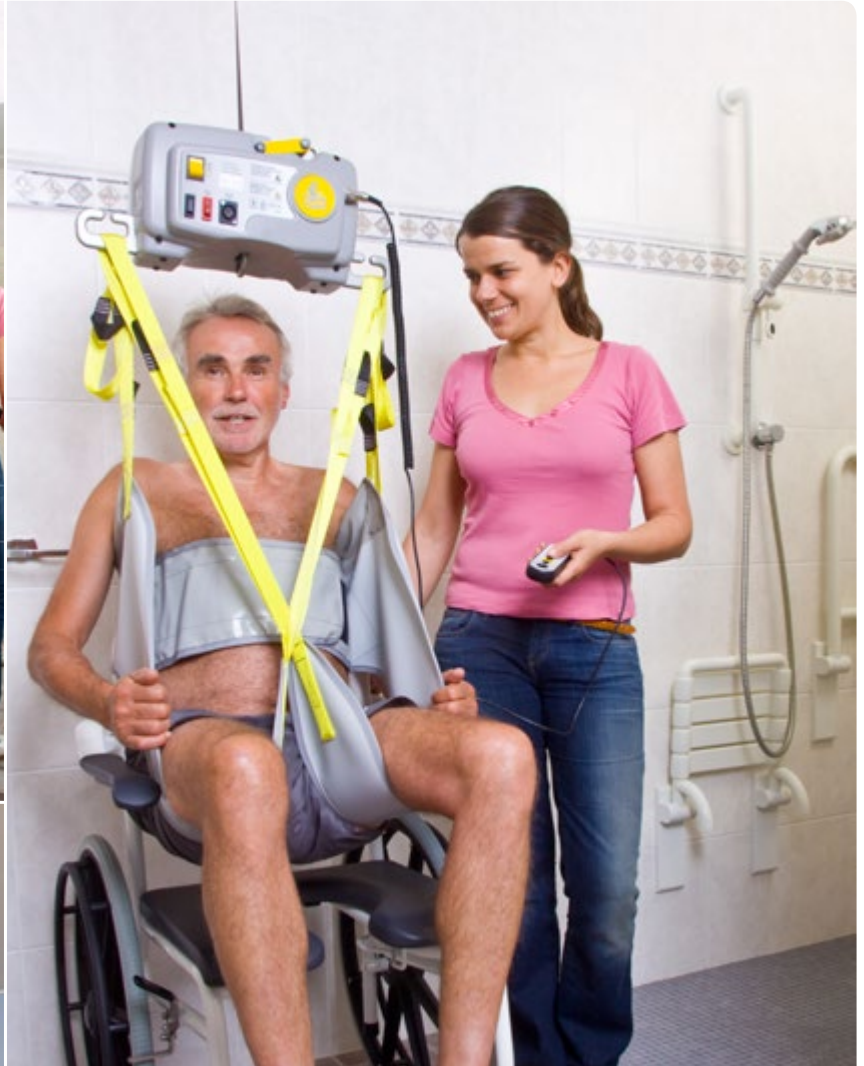

- Light & Compact
- Powerful, lifts up to 400 lbs
- Durable, gets you through multiple lifts between charges
- Built-in spreaderbar for Handi-Slings and built-in hook for SureHands® Body Support
- Manual control and/or control panel
- Emergency down feature
- Easy to use
- Budget friendly

Lift & Care systems for people with reduced mobility

www.surehands.com

Track-to-Track™ motor

● Track-to-Track motor with rail

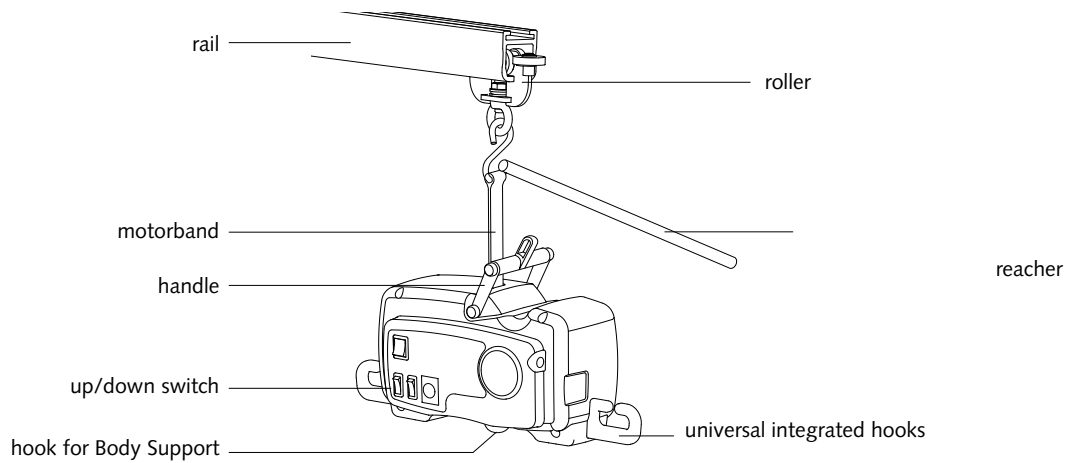

● Dimensions and specifications

Weight	17.5 Lbs - 8 kg
Max. Lifting Capacity	400 Lbs - 182 kg
Length.....	19.5 inch - 500 mm
Width.....	8 inch. - 200 mm
Height.....	8 inch. - 200 mm
Standard length of motorband.....	66.9 inch. - 1700 mm
Length of motorband outside motor.....	60.2 inch. - 1530 mm
Batteries	3 x 8 V
Capacity of batteries.....	3,2 Ah ea
Number of lifts with full batteries.....	65 x with 220 Lbs - 100 kg over a distance of 19.5 inch - 50 cm
Motor cover composition.....	ABS
Acceleration and deceleration	Electric
Overhead rail composition.....	Aluminum alloy, white laquered

● With Handi-slings or SureHands® Body Support

Thanks to the integrated hooks on both sides of the motor and the swivel hook placed centrally at the bottom, the motor can be used with all Handi-slings or with the Body Support.

Local Representative

Lift & Care® is a registered trademark of T.F. Herceg, Inc. dba SUREHANDS LIFT & CARE SYSTEMS.

© 30-11-2015 • Handi-Move • v1.2