

Model 1635

Foldable mobile lift

A budget friendly solution for home care



SUREHANDS®



- Compact and Reliable
- Foldable in one movement without disassembling
- Takes up less space for storage
- Smaller footprint makes it easier to transport to a second location
- Width adjustable base for easy positioning
- Low profile chassis with easy-to-roll castors for clearance under low objects

Specialists in innovative and reliable lift & care systems

www.surehands.com

Foldable mobile lift

● Dimensions (inch / mm)

A	51.85 / 1317
B	26.97 / 685
B'	20.39 / 518
B1	49.02 / 1245
C	20.87 / 530
D	4.33 / 110
H1	8.86 / 225
H2	66.34 / 1685
H3	75.59 / 1920
H4	17.72 / 450
L	47.44 / 1205
L'	15.16 / 385
L1	45.28 / 1150
L2	48.81 / 1240
T	22.83 / 580
T'	5.71 / 145

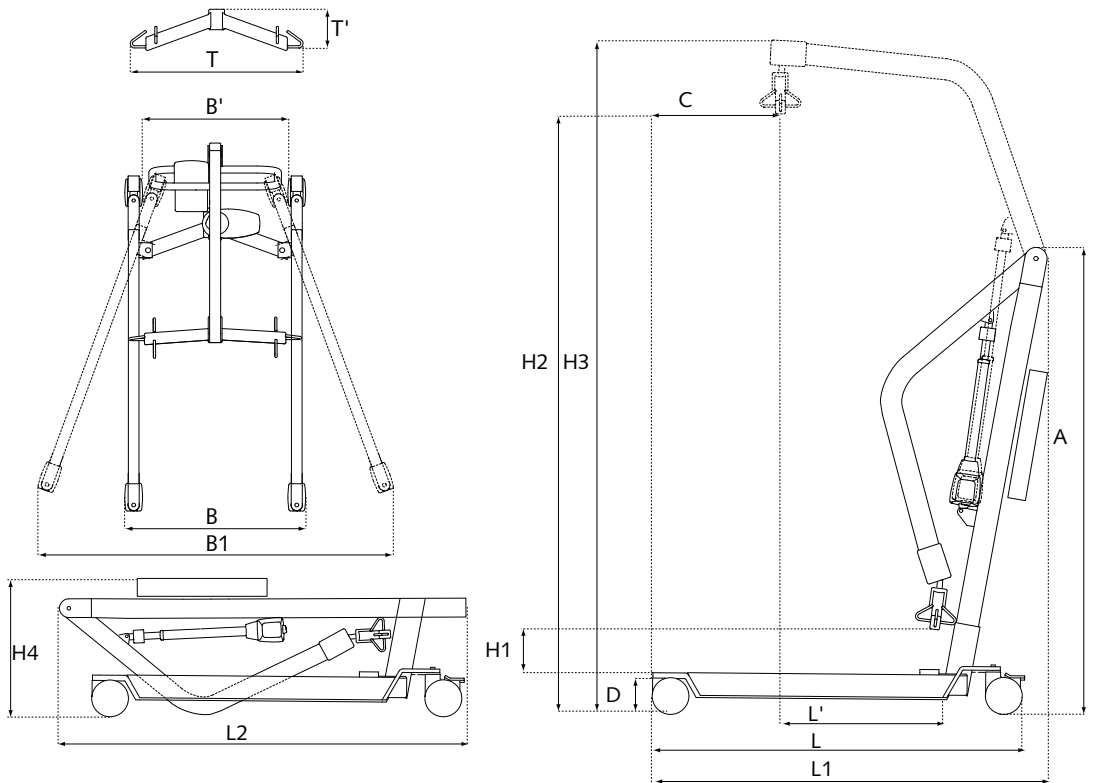

● Specifications

Max. lifting capacity	386 Lbs / 175 kg
Emergency down	mechanical
Weight	95 Lbs / 43 kg
Batteries	sealed and maintenance-free 2 x 12 volt 2,9 ah rechargeable
Number of lifts with fully charged batteries	40
Charger	Input: 0.9 A 100 - 240 Vac 50 -60 Hz, class II Output: 24 Vdc 250VA
Max. dimensions folded (L x W x H)	48.82 inch / 1240 mm x 26.97 inch / 685 mm x 17.72 inch / 450 mm

● Speed (inch / cm per sec.)

Raising (unloaded)	1.42 / 3.60
Lowering (unloaded)	1.42 / 3.60
Raising (load 198 Lbs / 90.00 kg)	1.14 / 2.90
Lowering (load 198 Lbs / 90.00 kg)	1.3 / 3.30
Raising (max. load)	0.91 / 2.30
Lowering (max. load)	1.18 / 3.00

Local Representative

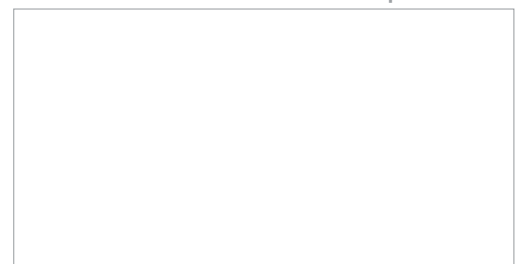

Lift & Care® is a registered trademark of T.F. Herceg, Inc. dba SUREHANDS LIFT & CARE SYSTEMS.

© 07-09-2015 • Handi-Move • v1.2